

# EV BUILDER'S GUIDE

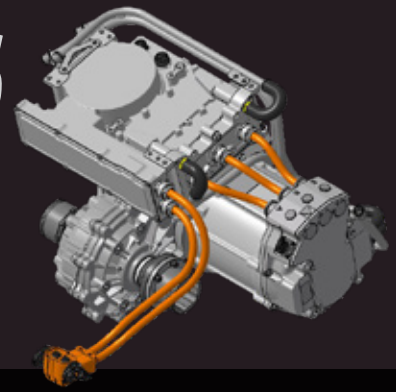

## Pioneer the EV Market

Electric vehicles and their buyers are increasing. New EVs are the future, which makes your brand recognition harder.

But now you have space in the world's first all-electric, resto-mod magazine: *EV Builder's Guide*. It will publish two issues a year starting May 31, 2022. Our readers trust every auto magazine we publish. And our EV coverage has everything to match your products:

- » The latest and greatest in EV aftermarket parts
- » Every build guide an EV buyer could want
- » The directory of global EV industry leaders and part suppliers
- » A deep-dive into the world's first EV certification program

*EV Builder's Guide* tracks the way electric motors are transforming classic and modern auto.

Now's the time to take this first step with us.



*Want to run ahead of the pack?*

Contact us before our ad close on **April 6!**

Gabe Frimmel

Advertising Sales Director

Phone: 800-332-3330 Ext 1930 | Email: [gfrimmel@engaged.media](mailto:gfrimmel@engaged.media)

**ENGAGED**<sup>®</sup>  
MEDIA, LLC

2220 Sedwick Rd, Durham, NC 27713